

Electronics 201

NANT

John Sweeny

Wednesday – March 7, 2012

Measuring Devices

- Thermistor
- Conductivity Cell
- Pressure Transducer
- Photoresistor

Material Conductance

- Insulators
 - Non crystalline material with few if any free electrons
 - Their resistances decrease with increasing temperature
- Conductors
 - Crystalline structure with many free electrons
 - Their resistances increase with increasing temperature
- Semiconductors
 - Not found in nature
 - Crystalline structure with the number of free electrons determined by added impurities
 - Resistance can be made to increase or decrease with increasing temperature.

It's all about energy levels

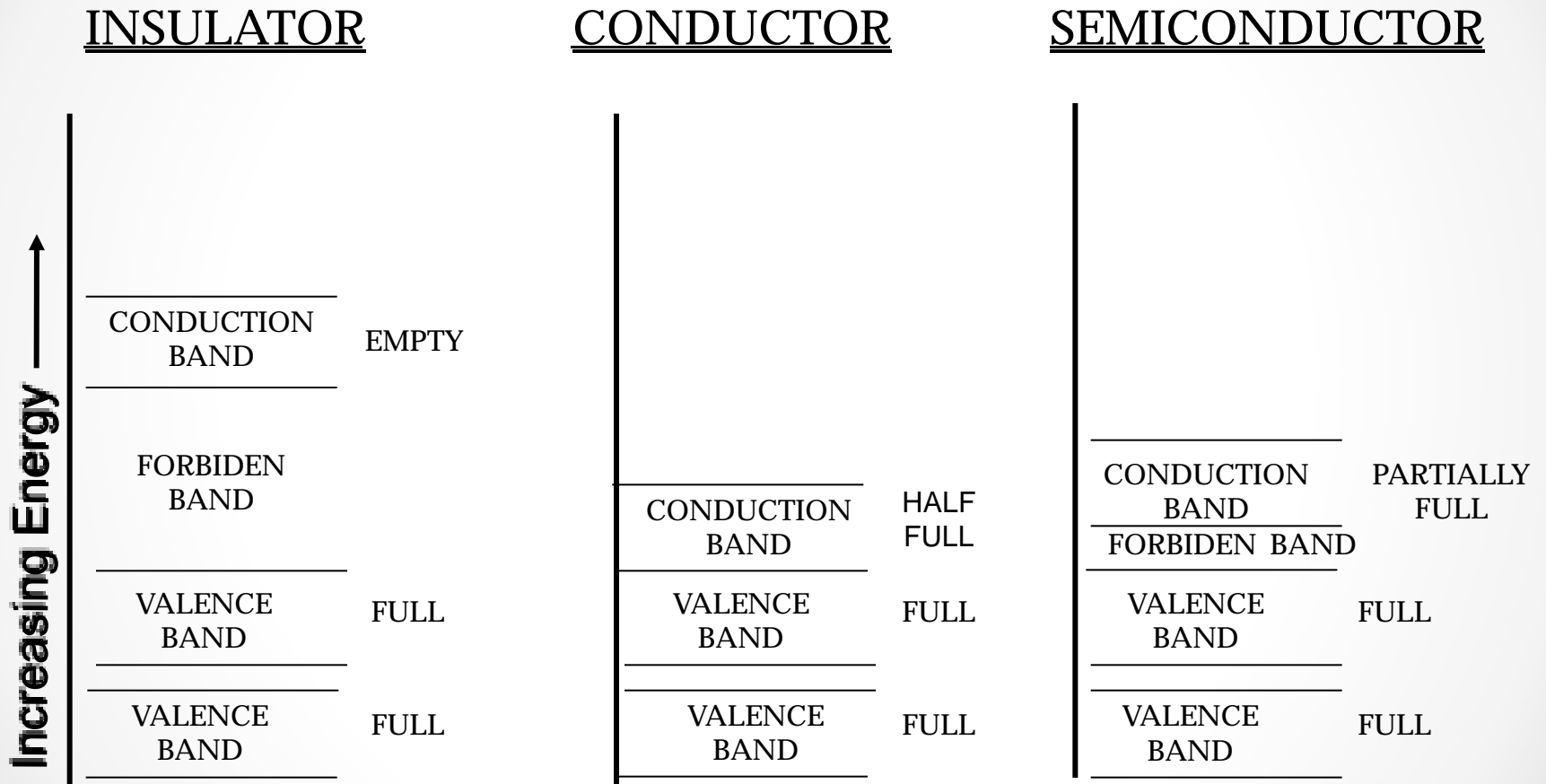

Thermistors

- The thermistor was invented by Samuel Ruben in 1930.
- Thermistors are made from ceramics or polymers
- A thermistor is a form of resistor that varies its resistance with temperature.

$$\Delta R = k \Delta T$$

Where: ΔR = change in resistance
 ΔT = change in temperature
 k = temperature coefficient

If k is positive, resistance increases with temperature and the thermistor has a positive temperature coefficient (PTC)

If k is negative, resistance decreases with temperature and the thermistor has a negative temperature coefficient (NTC)

A Typical NTC Thermistor

Temperature (°C)	Resistance (ohms)
20	2814
25	2252
30	1815
35	1471
40	1200
45	984

Steinhart-Hart Equation

- $1/T = A + B(\ln R) + C(\ln R)^3$
- Where:
- $T = \text{Kelvin}$, $R = \text{resistance}$, $A, B, C = \text{constants}$
- A, B, C are derived by measuring three data sets of Temperature and Resistance and solving the resulting three equations for $A, B,$ and C
- Picking temperatures within the range of -40°C and $+50^\circ \text{C}$ with temperatures differences of less than 50°C will yield a equation accuracy of 0.01°C or better

Thermistor Characteristics

- Standard Accuracy - +/- 0.2 °C over a range of 0 – 70 °C
- Time Constant – The time the thermistor takes to indicate 63% of a sudden change in temperature. The time constant x 5 is a measure of the full time to change to the new temperature (99.3%). A typical time constant is about 1 second.
- Dissipation constant – The power in milliwatts necessary to raise a thermistor's temperature 1° C above its surrounding temperature.

How a thermistor works

- Made from a disk or chip of semiconductor material consisting of sintered metal oxides
- When semiconductor materials are heated, the number of electrons that can move around within the material increases.
- These free electrons are said to be in the conduction band of the semiconductor
- The more free electrons, the higher the current

$$I = n \times A \times v \times e$$

where: I = electric current (ampere)

n = density of the charge carriers

A = cross-sectional area of the material

v = velocity of the charge carriers

e = charge on the electron (1.602×10^{-19} coulomb)

Thermistor Applications

- Temperature measurement – Monitor storage temperatures for drug manufacturers. Monitor dialysate temperature for conductivity measurement
- Current limiting in power supplies – They have high resistance when the power supply is first switched on, but then heat up (resistance drops) to allow higher currents after start up.
- Flow measurement – Current passing through a thermistor causes a temperature increase and hence a resistance change. The higher the flowrate, the more the cooling and hence the higher the resistance

Electrical Conductivity

- Also known as specific conductivity.
- Conductivity is the ratio of current density to electrical field strength
- It is a measure of a material's ability to conduct an electrical current
- It's unit of measure is Siemens/meter with the symbol s
- For water systems the common unit is millisiemens/cm
- It is the reciprocal of electrical resistivity
- 1 Siemens/meter is the conductance between two one square meter plates one meter apart.

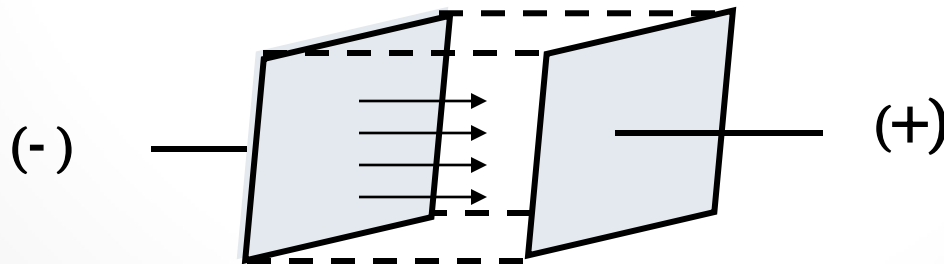

Conductivity Temperature Compensation

Table for 14.0 mS/cm @ 25° C

Temperature (degrees C)	Uncompensated Cond. (mS/cm)	% Change From 37.0° C
34.0	16.83	-6.31
35.0	17.18	-4.18
36.0	17.54	-2.07
37.0	17.90	0.00
38.0	18.27	2.07
39.0	18.65	4.18
40.0	19.03	6.31

Dialysis Technology – A Manual for Dialysis Technicians, 3rd Edition, Jim Curtis & Philip Varughese, © 2003, National Association of Technicians/Technologists, p 200.

Conductivity of Dialysate

- Unit of Measure: milliSiemens/centimeter
- Used to measure total ion concentration
- Factors that determine conductivity:
 - Each ion based on its mobility and charge
 - Total ions in solution (ion interaction)
 - Non ionic molecules (Dextrose) reduce the effect about 0.5 %
 - Dependent on Temperature (Reference 25° C)
 - Typical value for dialysate: 14.0 mS/cm

Cell Constant

- A cell constant is the distance between electrodes divided by electrode surface area
- For electrodes 1 cm square and 1 cm apart, the cell constant would be: $1 \text{ cm}/1 \text{ cm}^2 = 1 \text{ cm}^{-1}$
- Dialysate conductivity is about 14.0 mS/cm @ 25°C
- Think of this as cell conductance of 14.0 mS multiplied by a cell constant of 1 cm^{-1}
- $14.0 \text{ mS} \times 1 \text{ cm}^{-1} = 14.0 \text{ mS/cm} = 71.4 \text{ ohm-cm}$

Difference size cells – same result

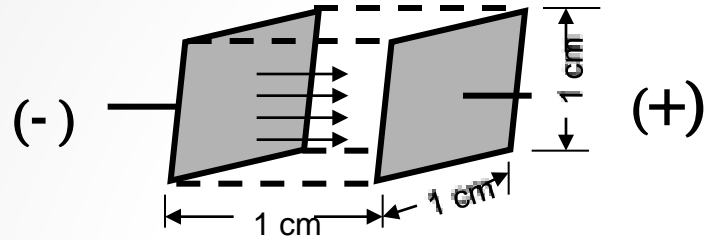

Conductance = 14 mS
 Cell Constant = 1 cm^{-1}
 Conductivity = 14 mS/cm

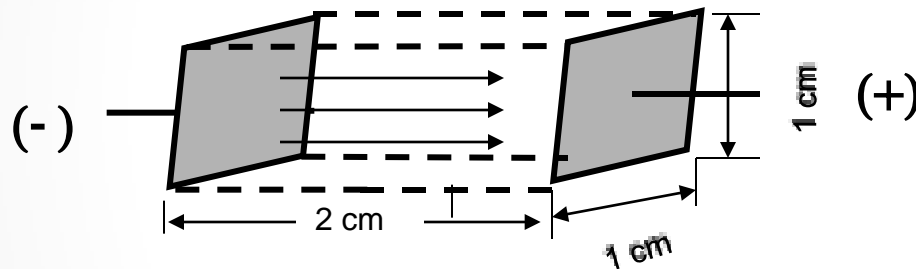

Conductance = 7.0 mS
 Cell Constant = 2 cm^{-1}
 Conductivity = 14 mS/cm

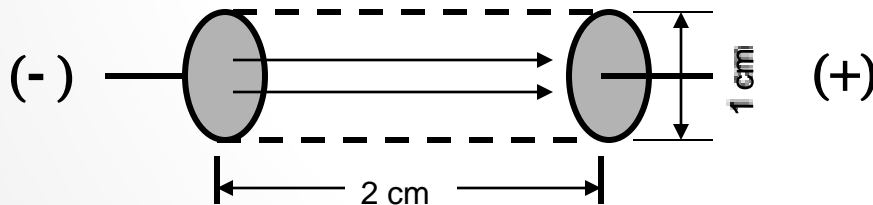

Conductance = 5.5 mS
 Cell Constant = 2.57 cm^{-1}
 Conductivity = 14 mS/cm

Conductivity = Conductance x Cell Constant

STANDARD SOLUTIONS

- All reference solutions must adhere to national standards
- In the United States those standards are administered by the National Institute of Standards and Technology (NIST)
 - Primary standard – calibrated to NIST standards measuring equipment guidelines
 - Secondary standard – Tested against a measuring instrument calibrated using primary standards
 - Working solutions – Tested against a measuring instrument calibrated using secondary standards
- 1993 – International Organization for Standardization published a guideline defining measurement of uncertainty.
 - ISO Guide for Measurement Uncertainty
 - Accuracy = Uncertainty/2
 - Measuring instrumentation is only as good as the standards used for calibration

Machine Conductivity Circuit

INPUTS

OUTPUT

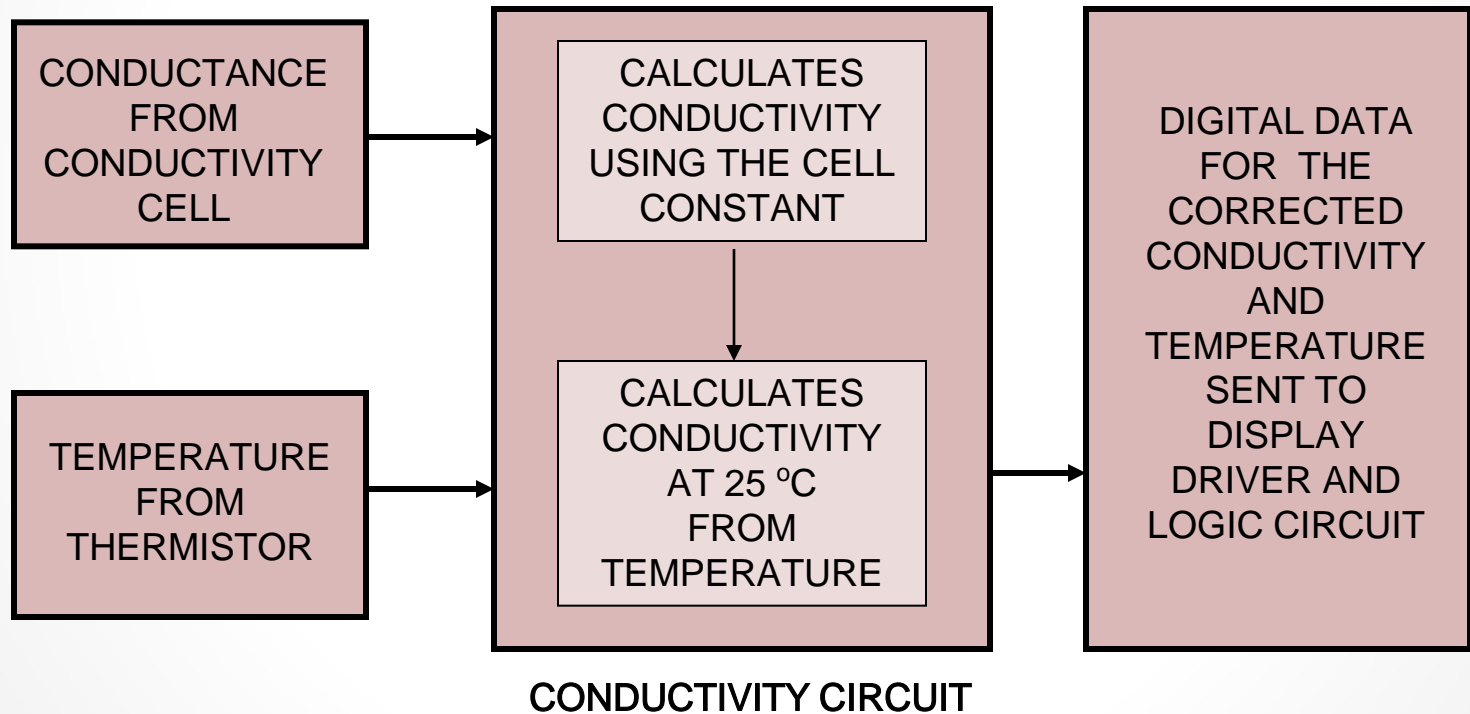

Pressure Transducers

- Pressure – Force per unit of area. Unit of measure in the MKS system is the Pascal. In medical practice the pressure unit is the mmHg. 1 mmHg = 133.32 Pa
- Transducer – Any device that converts an input signal into an output signal of a different form
- Types of pressure transducer technologies:
 - Fiber Optic – fibers arranged at right angles to form an interferometer. Can read displacements of a membrane at nanometer (10^{-9}) lengths
 - Mechanical deflection – pressures create small deflections which can be amplified to cause meter needle rotation.
 - Strain gauge – some crystalline materials will either change their internal resistance or create small voltages when stressed
 - Semiconductor piezoresistive effect – semiconductors can change their conductivity when pressure is applied.

Why use a Silicone Piezoresistor?

- High sensitivity – 100x higher change with stress than metal types
- The resistor is diffused into the silicone. No bonding of different materials causing thermo-elastic strain
- Silicone is a pure crystal and doesn't become permanently stretched
- Forms more elastic disks than metal.
- Lower hysteresis – silicone returns to its original shape when the pressure is removed

Silicone disk with Piezoresistors

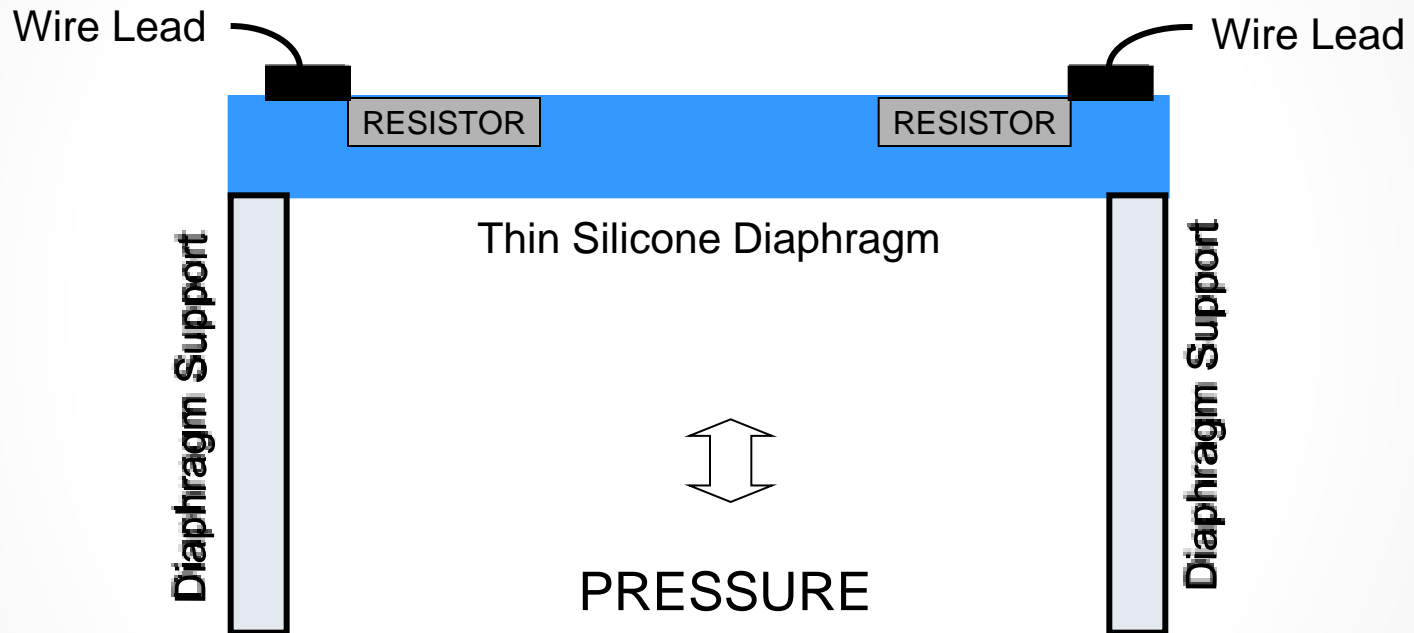

When the diaphragm is stressed, the diffused resistor resistance will change. The resistance can either increase or decrease depending on the orientation of the resistor to the silicone crystal lattice.

Transducer Network

4 Piezoresistors

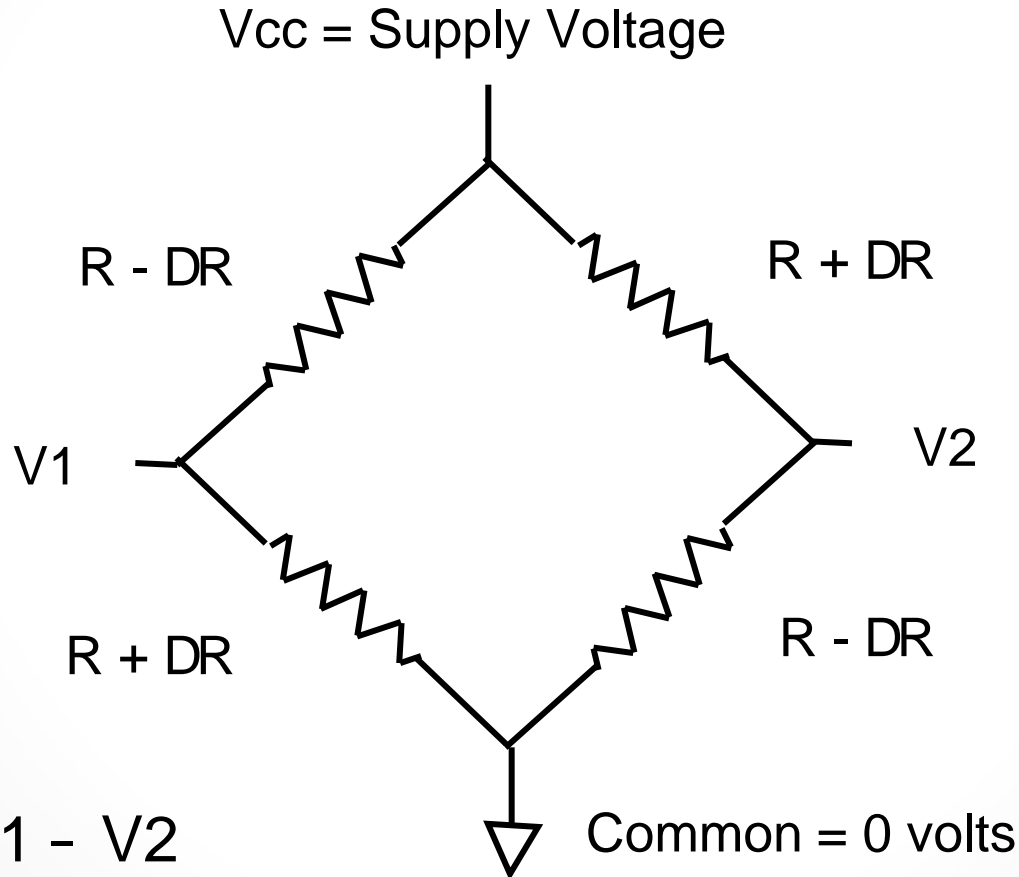

Output = $V1 - V2$

Common = 0 volts

Photoresistor

- A semiconductor device whose resistance is dependent on light.
- Increasing light striking the device will result in a lower resistance
- There are two types:
 - Intrinsic – has its own charge carriers and is not very responsive to light unless the light has high energy. Pure Silicon is a good example
 - Extrinsic – Has impurities (dopants) which create electrons with more energy within the crystal. Light with lower energy will cause resistance changes. Silicon with Phosphorus added is an example.

How fast do the electrons
move down a wire in a
dialysis machine's power cord
during a dialysis treatment?

Free electrons

- 1 cc of Copper contains 8×10^{22} free electrons at room temperature*
 - Gram molecular weight of Copper = 63.54
 - 1 mole ($N_A = 6.02 \times 10^{23}$) atoms of Copper = 63.54 grams
 - Density of Copper = 8.96 gm/cm
- How many Copper atoms in 1 cc ?
 - $8.96/63.54 = 0.141$ mole
 - $0.141 \times 6.02 \times 10^{23} = 8.49 \times 10^{22}$ Copper atoms
- How many electrons per atom?
 - $8 \times 10^{22}/8.49 \times 10^{22} = 0.942$ electrons/atom of Copper
- For every Copper atom in a wire, there is one free electron at room temperature

* University Physics, F. W. Sears and M. W. Zemansky, Copyright 1949, Addison-Wesley Press, Page 397

Copper Wire Characteristics

Size AWG	Current (ampere)	Diameter (mm)	Resistance (feet/ohm)
12	20	2.053	617.3
14	15	1.628	387.6
16	10	1.291	244.5

Electrons in a Power Cord

- Sizing things up:

- A dialysis machine power cord uses 14 AWG copper wire.
- Power cord length = 10 feet = 3.05 meters = 305 cm
- The volume of wire in the power cord would be:

$$V = LpD^2/4$$

$$V = (305 \text{ cm}) \times p \times (0.163 \text{ cm})^2/4$$

$$V = 6.36 \text{ cm}^3$$

- The amount of Copper:

- Mass = Density x Volume = $8.96 \text{ gm/cm}^3 \times 6.36 \text{ cm}^3$
= 56.98 grams
- Number of Copper atoms = $(56.98 \text{ gm}/63.54 \text{ gm}) \times N_A$
= 5.40×10^{23} atoms
- # of Copper atoms = # of electrons = 5.40×10^{23} electrons

A Word about Current

- The unit of current is the ampere
- Andre Marie Ampere (1775–1836) – French physicist and mathematician. Founder of electrodynamics. Related current to magnetic field strength.
- Current is the rate that charge moves past a point or region
- The unit of charge is the coulomb
- A current of one ampere is equal to a coulomb of charge moving past a cross section of wire in one second
- The charge on an electron is 1.60×10^{-19} coulomb
- One coulomb consists of 6.25×10^{18} electrons
- One ampere is a flow of 6.25×10^{18} electrons/second

Electrons Flow in the Power Cord

- Electrons in power cord/Electrons in one coulomb
- 5.40×10^{23} electrons/ 6.25×10^{18} electrons = 8.60×10^4 coulomb
- Electrons move at an average speed of 1.6×10^6 m/s, but this speed is random with a net effective speed of zero m/s
- When an electrical field is applied along the wire (voltage), the electrons will drift in the wire.
- If a typical dialysis machine runs on 13 ampere, then the rate at which the electrons will move is 13 coulomb/second
- How long would it take to empty the power cord?
 - 8.60×10^4 coulomb/13 coulombs/second = 6,615 seconds
= 1 hour, 50 seconds
 - 10 ft/1.83 h = 5.46 ft/h = 1 mile/967 h = 9.05 miles/year !!
 - 3.05 m/1.84 h = 1.66 m/h = 1 km/602 h = 14.55 km/year !!